

THIS DRAWING IS UNPUBLISHED. RELEASED FOR PUBLICATION
 © COPYRIGHT BY TYCO ELECTRONICS CORPORATION. ALL RIGHTS RESERVED.

LOC	DIST	REVISIONS			
P	LTR	DESCRIPTION	DATE	DWN	APVD
AF	50	D	REVISED PER ECR-06-010412	31OCT06	HMR KR

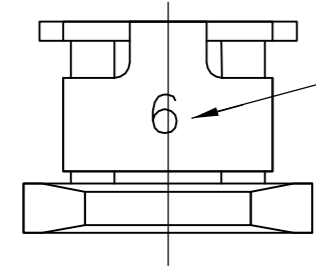

- 1 SLOT TERMINATES EITHER A SINGLE OR DOUBLE MAGNET WIRE OF THE SAME SIZE AND TYPE. COPPER RANGE: 0.25-0.36mm [#30-#27] AWG.
- 2 AFTER INSERTION INTO PLASTIC HOLDER TAB PORTION MUST BE BENT OVER 45° TO 90° OR POTTED-IN TO PERVENT PULL-OUT WHEN MATING RECEPTACLE IS DISCONNECTED.

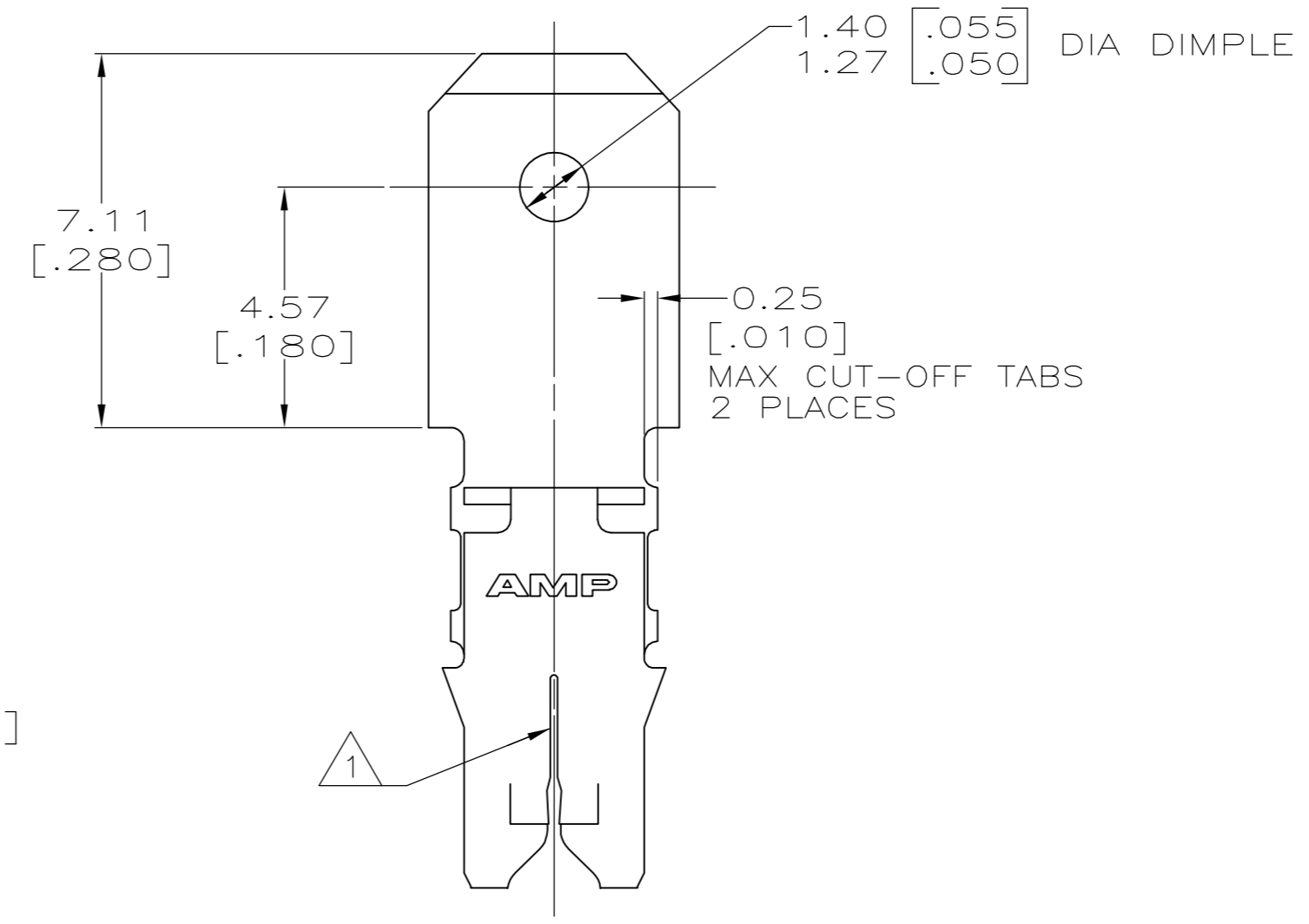
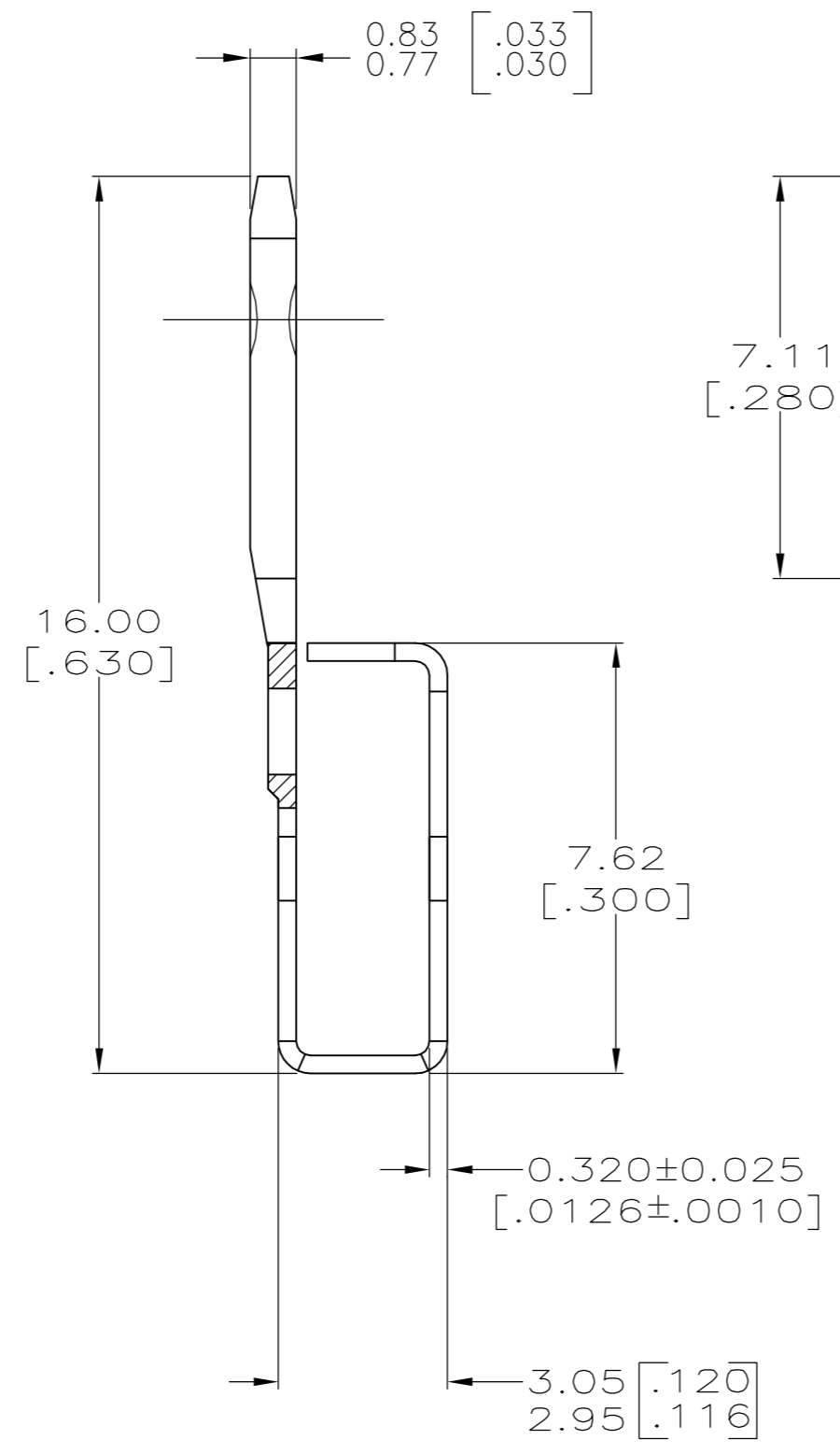
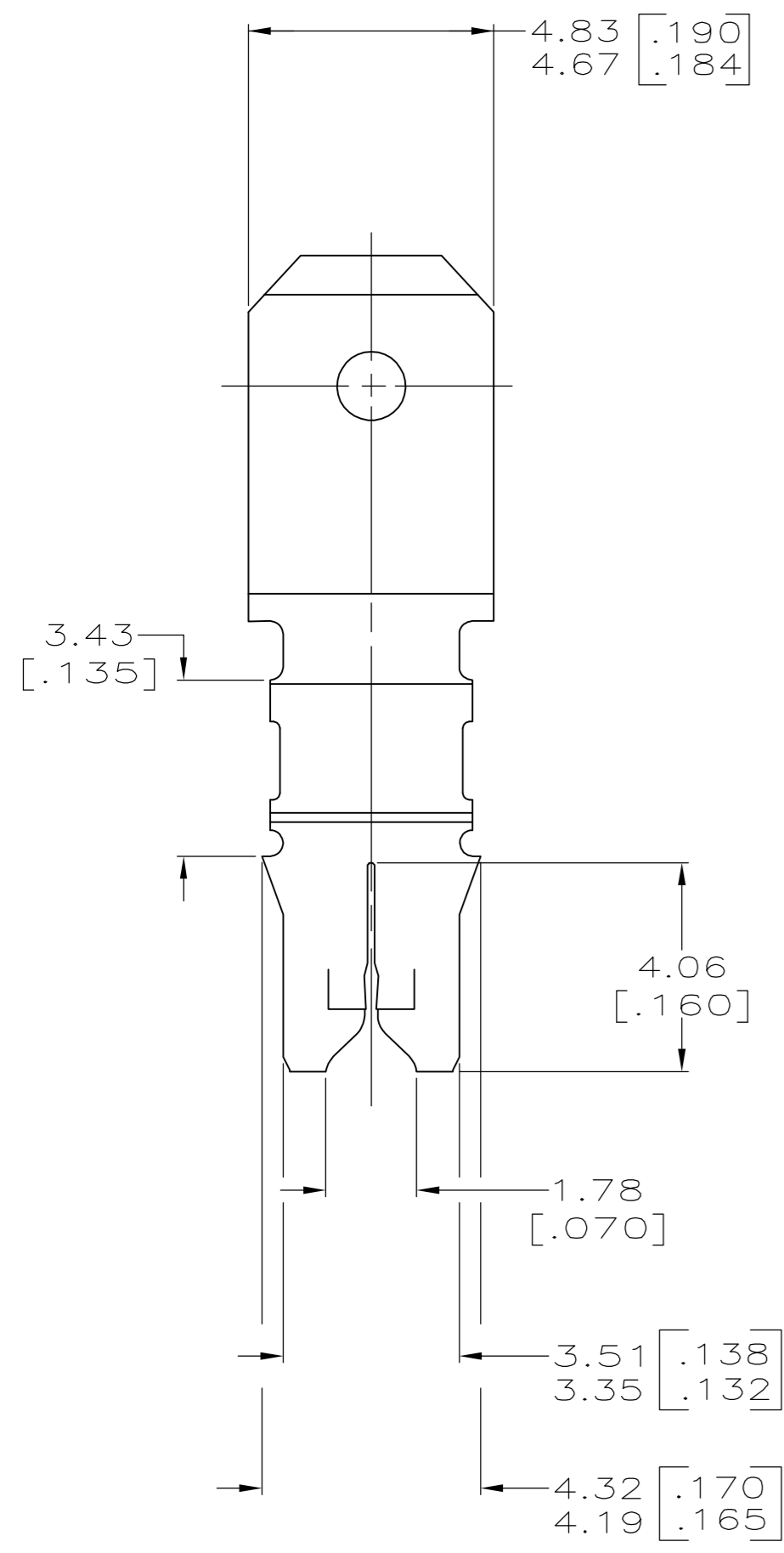

1217178-1
 PART NUMBER

THIS DRAWING IS A CONTROLLED DOCUMENT.		DWN MICHAEL S. FEHER 08JUN1999	Tyco Electronics Corporation Harrisburg, PA 17105-3608	
DIMENSIONS: mm [INCHES]		CHK KURT A. RANDOLPH 08JUN1999		
TOLERANCES UNLESS OTHERWISE SPECIFIED:		APVD KURT A. RANDOLPH 08JUN1999	NAME KURT A. RANDOLPH	
0 PLC ± - 1 PLC ± - 2 PLC ± 0.25 [.010] 3 PLC ± - 4 PLC ± - ANGLES ± - FINISH		PRODUCT SPEC 108-2012	TERMINAL, TAB, 4.75[.187] FASTON, LOOSE PIECE, 300 SERIES MAG-MATE	
MATERIAL H02 PRE-MILLED BRASS		APPLICATION SPEC 114-2046	SIZE A2	CAGE CODE 00779
0.002032[.000080] MIN TIN PLATE		WEIGHT -	DRAWING NO C=1217178	RESTRICTED TO -
CUSTOMER DRAWING			SCALE 8:1	SHEET 1 of 1
			REV D	